

# Autonomous and Adaptive Systems

## Introduction to Deep Learning and Neural Architectures II

Mirco Musolesi

[mircomusolesi@acm.org](mailto:mircomusolesi@acm.org)

# Computers and Brains

|                     | Supercomputer                               | Personal Computer                           | Human Brain                             |
|---------------------|---------------------------------------------|---------------------------------------------|-----------------------------------------|
| Computational units | $10^6$ GPUs + CPUs<br>$10^{15}$ transistors | 8 CPU cores<br>$10^{10}$ transistors        | $10^6$ columns<br>$10^{11}$ neurons     |
| Storage units       | $10^{16}$ bytes RAM<br>$10^{17}$ bytes disk | $10^{10}$ bytes RAM<br>$10^{12}$ bytes disk | $10^{11}$ neurons<br>$10^{14}$ synapses |
| Cycle time          | $10^{-9}$ sec                               | $10^{-9}$ sec                               | $10^{-3}$ sec                           |
| Operations/sec      | $10^{18}$                                   | $10^{10}$                                   | $10^{17}$                               |

From: Stuart Russell and Peter Norvig. Introduction to Artificial Intelligence. 4th Edition. 2020.

# From Theories of Biological Learning to Deep Learning

- ▶ Three waves:
  - ▶ Cybernetics (1940s-1960s)
  - ▶ Connectionism (1980s-1990s)
  - ▶ Deep learning (2006-today)
- ▶ Some of the earliest learning algorithms were intended to be computational models of the brain. As a result, one of the names used for deep learning is *artificial neural networks (ANNs)*.

# Cybernetics

or CONTROL and COMMUNICATION  
in THE ANIMAL and THE MACHINE

By NORBERT WIENER

A study of vital importance to psychologists,  
physiologists, electrical engineers, radio engineers,  
sociologists, philosophers, mathematicians, anthro-  
pologists, psychiatrists, and physicists.

# Artificial Neural Networks and Neuroscience

- ▶ The earliest predecessors of modern deep learning were simple linear models motivated from a neuroscience perspective.
- ▶ These models were designed to take a series of  $n$  input values  $x_1, x_2, \dots, x_n$  and associate them to an output  $y$ .
- ▶ These models would be based or learn a set of weights:  
$$y = f(\mathbf{x}, \mathbf{w}) = w_1x_1 + \dots + w_nx_n$$

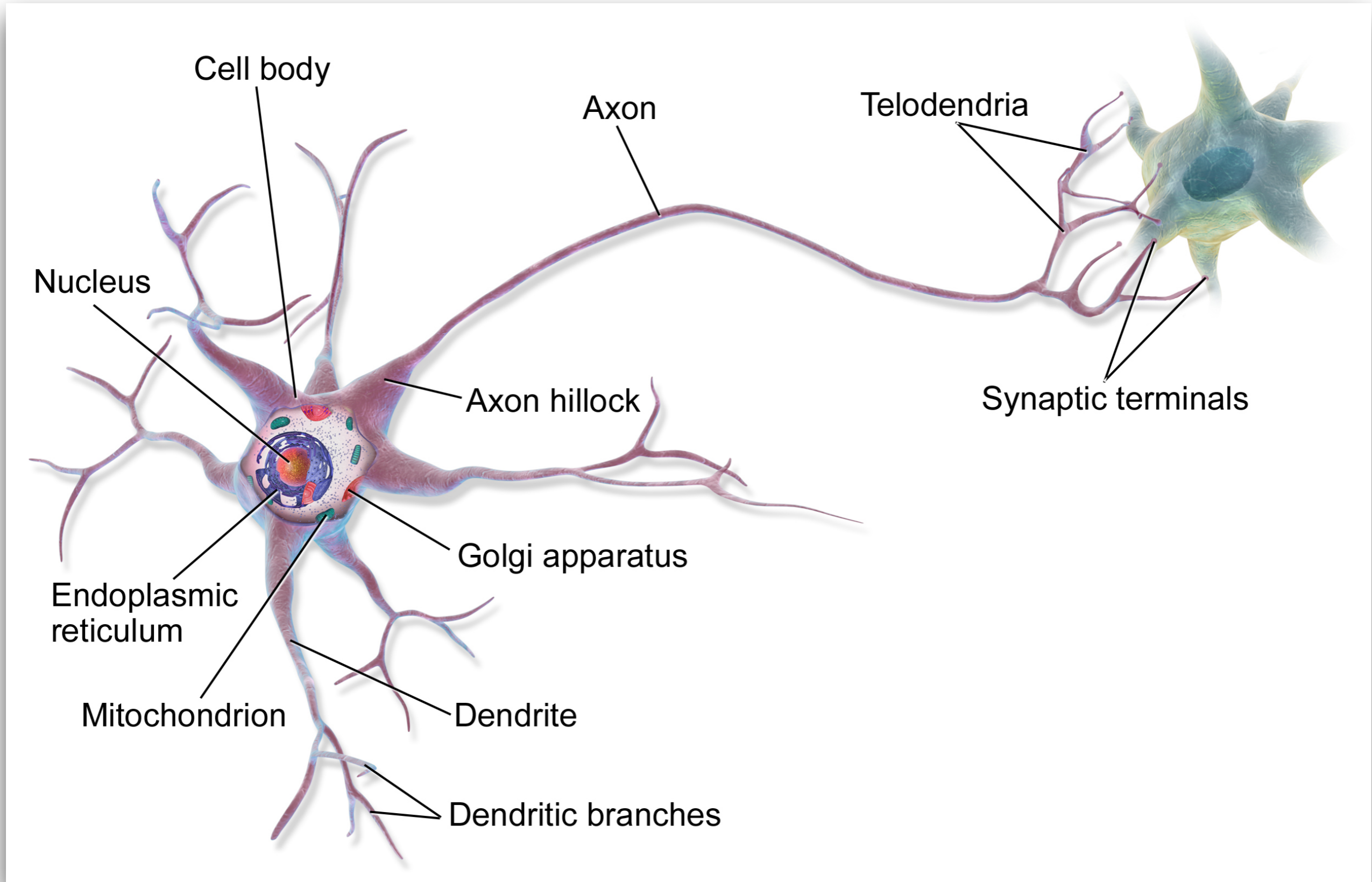

Credit: Wikimedia

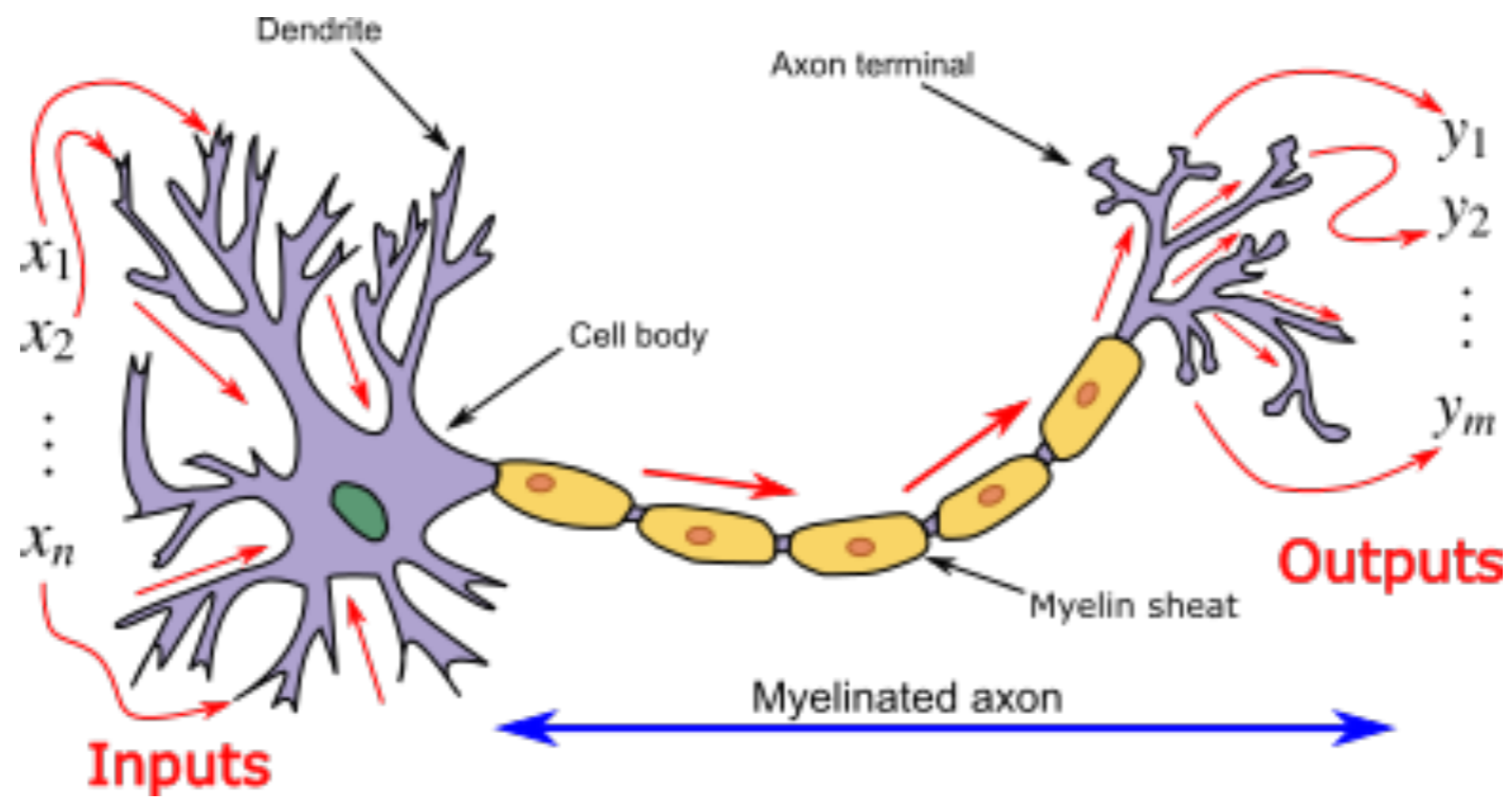

Credit: Wikimedia

BULLETIN OF  
MATHEMATICAL BIOPHYSICS  
VOLUME 5, 1943

## A LOGICAL CALCULUS OF THE IDEAS IMMANENT IN NERVOUS ACTIVITY

WARREN S. MCCULLOCH AND WALTER PITTS

FROM THE UNIVERSITY OF ILLINOIS, COLLEGE OF MEDICINE,  
DEPARTMENT OF PSYCHIATRY AT THE ILLINOIS NEUROPSYCHIATRIC INSTITUTE,  
AND THE UNIVERSITY OF CHICAGO

Because of the "all-or-none" character of nervous activity, neural events and the relations among them can be treated by means of propositional logic. It is found that the behavior of every net can be described in these terms, with the addition of more complicated logical means for nets containing circles; and that for any logical expression satisfying certain conditions, one can find a net behaving in the fashion it describes. It is shown that many particular choices among possible neurophysiological assumptions are equivalent, in the sense that for every net behaving under one assumption, there exists another net which behaves under the other and gives the same results, although perhaps not in the same time. Various applications of the calculus are discussed.

### *I. Introduction*

Theoretical neurophysiology rests on certain cardinal assumptions. The nervous system is a net of neurons, each having a soma and an axon. Their adjunctions, or synapses, are always between the axon of one neuron and the soma of another. At any instant a neuron has some threshold, which excitation must exceed to initiate an impulse. This, except for the fact and the time of its occurrence, is determined by the neuron, not by the excitation. From the point of excitation the impulse is propagated to all parts of the neuron. The velocity along the axon varies directly with its diameter, from less than one meter per second in thin axons, which are usually short, to more than 150 meters per second in thick axons, which are usually long. The time for axonal conduction is consequently of little impor-



get the other and gives the same results, although perhaps not at the same time. Various applications of the calculus are discussed.

### *I. Introduction*

Theoretical neurophysiology rests on certain cardinal assumptions. The nervous system is a net of neurons, each having a soma and an axon. Their adjunctions, or synapses, are always between the axon of one neuron and the soma of another. At any instant a neuron has some threshold, which excitation must exceed to initiate an impulse. This, except for the fact and the time of its occurrence, is determined by the neuron, not by the excitation. From the point of excitation the impulse is propagated to all parts of the neuron. The velocity along the axon varies directly with its diameter, from less than one meter per second in thin axons, which are usually short, to more than 150 meters per second in thick axons, which are usually long. The time for axonal conduction is consequently of little importance in determining the time of arrival of impulses at points unequally remote from the same source. Excitation across synapses occurs predominantly from axonal terminations to somata. It is still a moot point whether this depends upon irreciprocity of individual synapses or merely upon prevalent anatomical configurations. To suppose the latter requires no hypothesis *ad hoc* and explains known exceptions, but any assumption as to cause is compatible with the calculus to come. No case is known in which excitation through a single synapse has elicited a nervous impulse in any neuron, whereas any

# The McCulloch-Pitts Neural Model

- ▶ In “A Logical Calculus of the Ideas Imminent in Nervous Activity” (1943), McCulloch and Pitts suggested a mathematical cognitive model.
- ▶ This can be considered the original inspiration of current deep learning models.
- ▶ The set of operations is defined over two values:
  - ▶ True (1)
  - ▶ False (0)
- ▶ The calculus contained NOT, AND, OR. By changing the (fixed) values of the weights, you can obtain different functions.

# McCulloch-Pitts Model of Neuron

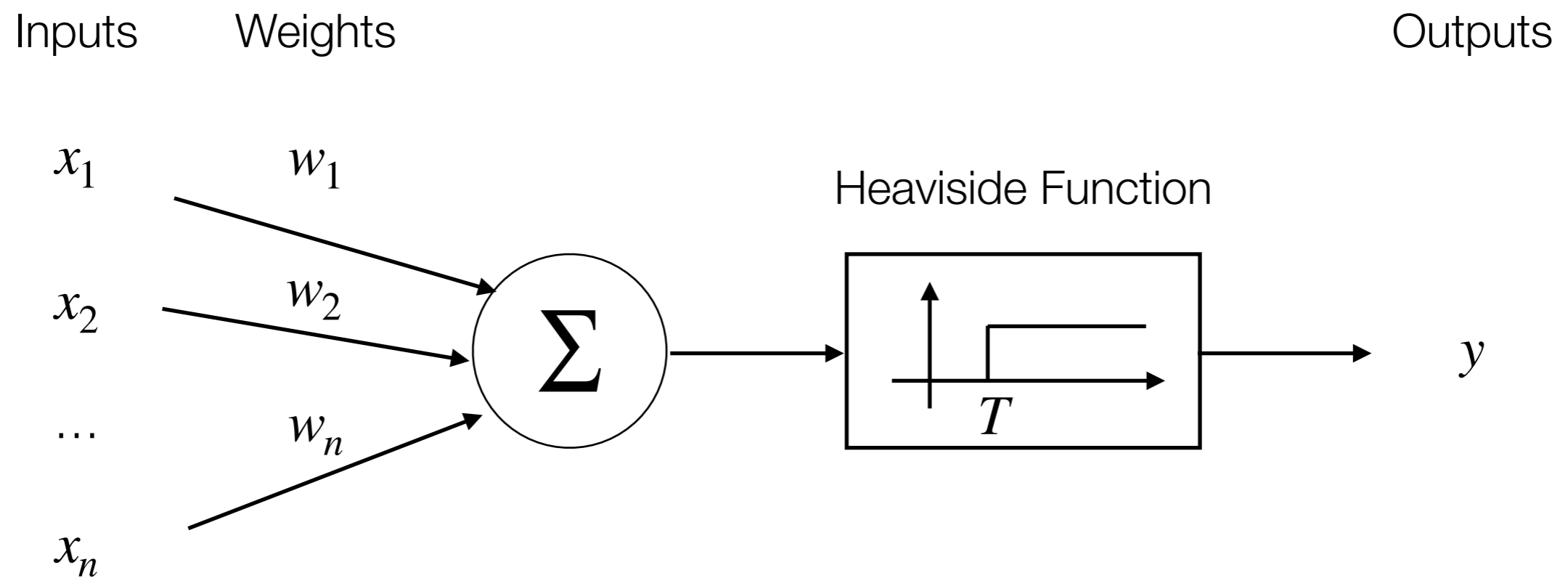

In the McCulloch-Pitts model, the values of the weights are fixed.

# *The Organization of Behavior*

A NEUROPSYCHOLOGICAL THEORY

D. O. HEBB

*McGill University*

1949

*New York · JOHN WILEY & SONS, Inc.*

*London · CHAPMAN & HALL, Limited*

# Hebb's Law

- ▶ From Hebb's "The Organization of Behavior" (1949): "When an axon cell  $A$  is near enough to excite cell  $B$  and repeatedly or persistently takes part in firing it, some growth process or metabolic change takes place in one or both cells such as that  $A$ 's efficiency, as one of the cells firing  $B$  is increased".
- ▶ This is usually referred to as "Hebb's Law".
- ▶ First simulations of artificial neural networks in 1950s based on Hebb's model.
- ▶ Weights of the models are also called synaptic connectivity.

# Hebb's Model of Neuron

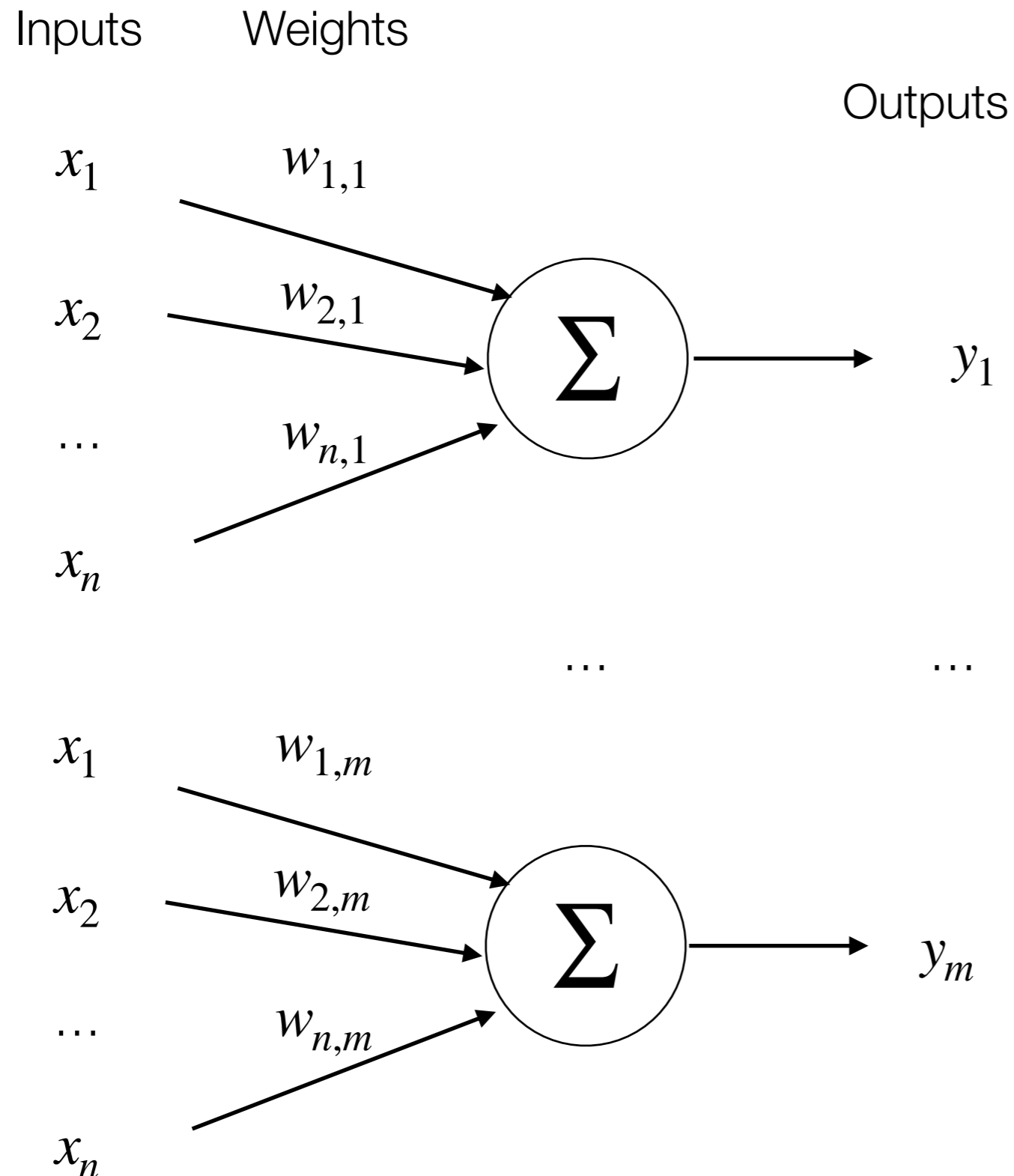

The Hebbian network model has  $n$ -node input layer:

$$\mathbf{x} = [x_1, x_2, \dots, x_n]^T$$

and an  $m$ -node output layer

$$\mathbf{y} = [y_1, y_2, \dots, y_m]^T$$

Each output is connected to all input as follow:

$$y_i = \sum_{j=1}^n w_{j,i} x_j$$

The learning rule is the following:

$$w_{j,i}^{new} \leftarrow w_{j,i}^{old} + \eta x_j y_i$$

$\eta$  is the learning rate.

## THE PERCEPTRON: A PROBABILISTIC MODEL FOR INFORMATION STORAGE AND ORGANIZATION IN THE BRAIN<sup>1</sup>

F. ROSENBLATT

*Cornell Aeronautical Laboratory*

If we are eventually to understand the capability of higher organisms for perceptual recognition, generalization, recall, and thinking, we must first have answers to three fundamental questions:

1. How is information about the physical world sensed, or detected, by the biological system?
2. In what form is information stored, or remembered?
3. How does information contained in storage, or in memory, influence

and the stored pattern. According to this hypothesis, if one understood the code or "wiring diagram" of the nervous system, one should, in principle, be able to discover exactly what an organism remembers by reconstructing the original sensory patterns from the "memory traces" which they have left, much as we might develop a photographic negative, or translate the pattern of electrical charges in the "memory" of a digital computer. This hypothesis is appealing in its simplicity and ready intelligibility,

# Rosenblatt's Perceptron Model

- ▶ Frank Rosenblatt's perceptron models the first one with variable weights that were learned from examples:
  - ▶ Learning the weights of categories given examples of those categories.
- ▶ The perceptron was intended to be a machine rather than a program.
  - ▶ First implementation was actually for IBM 704.



# IBM 704



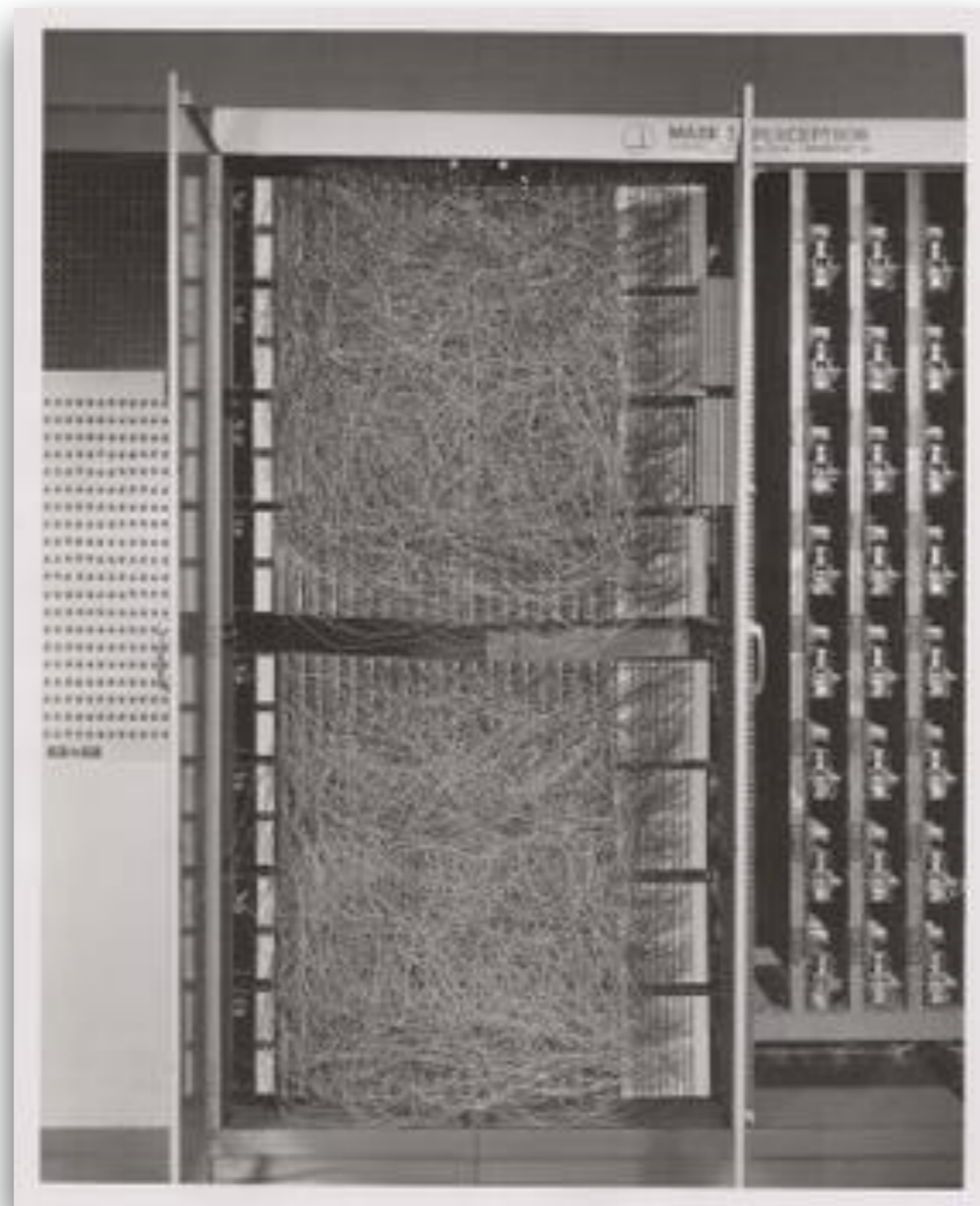

## Mark I Perceptron

Built for image recognition

400 photocells randomly connected to the neurons

Weights encoded in potentiometers

# Limitations of Perceptrons

- ▶ Linear models have many limitations.
- ▶ Most famously, they cannot learn the XOR function where  $f([0,1], \mathbf{w}) = 1$  and  $f([1,0], \mathbf{w}) = 1$  but  $f([1,1], \mathbf{w}) = 0$  and  $f([0,0], \mathbf{w}) = 0$ .
- ▶ This was observed by Minsky and Papert in 1969 in *Perceptrons*.
- ▶ This was the first major dip in the popularity of neural networks.

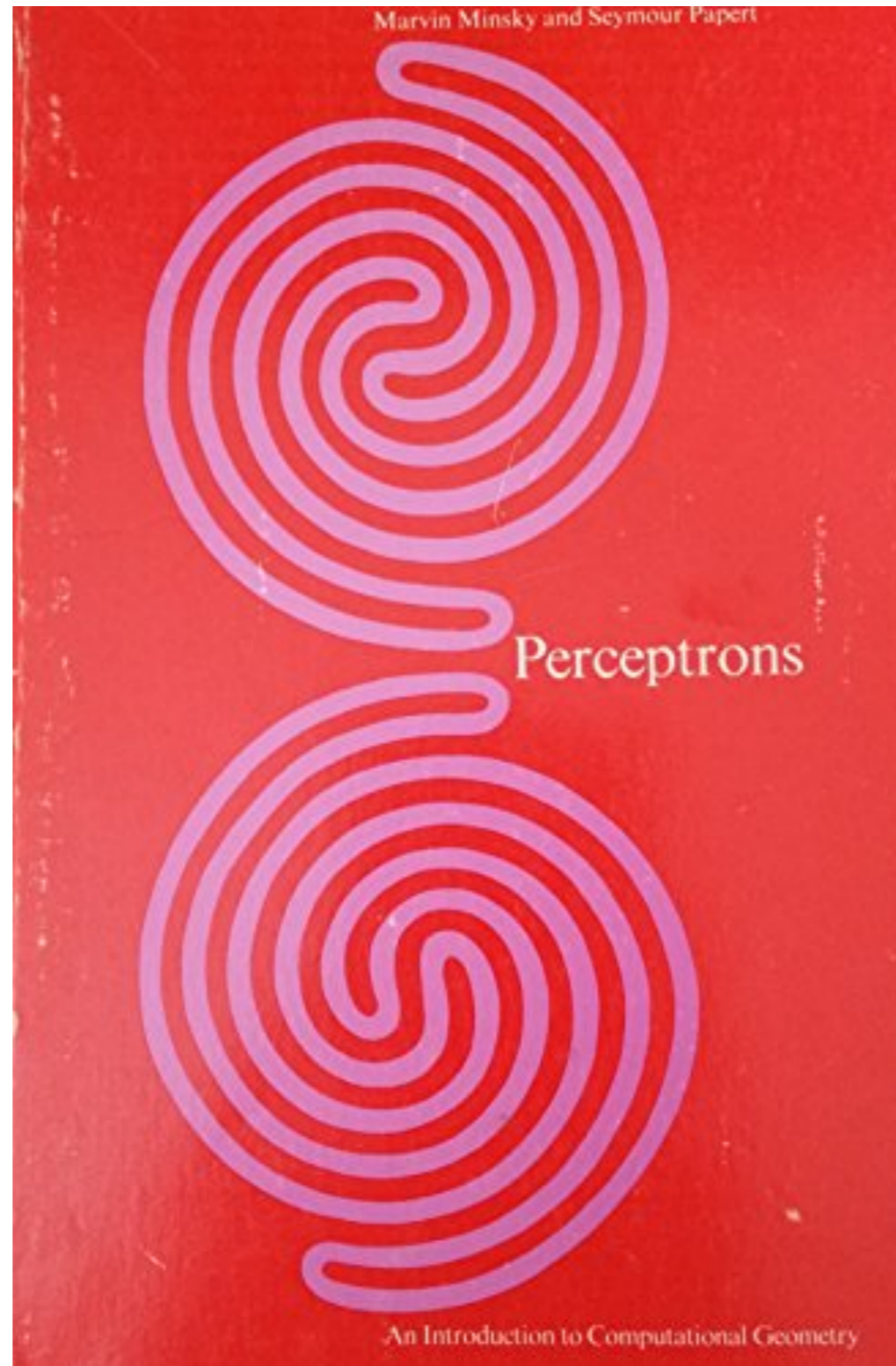

# Neurocognitron and Convolutional Neural Networks

- ▶ Neuroscience can be an inspiration for the design of novel architectures and solutions.
- ▶ The basic idea of having multiple computational units that become intelligent via their interactions with each others is inspired by the brain.
- ▶ The *neurocognitron* introduced by Fukushima can be considered as a basis for the modern convolutional networks architectures.
- ▶ The neurocognitron was the basis of the modern convolutional network architectures (see Yann LeCun et al.'s LeNet architecture).

## Cognitron: A Self-organizing Multilayered Neural Network

Kunihiko Fukushima

NHK Broadcasting Science Research Laboratories, Kinuta, Setagaya, Tokyo, Japan

Received: February 4, 1975

### Abstract

A new hypothesis for the organization of synapses between neurons is proposed: "The synapse from neuron  $x$  to neuron  $y$  is reinforced when  $x$  fires provided that no neuron in the vicinity of  $y$  is firing stronger than  $y$ ". By introducing this hypothesis, a new algorithm with which a multilayered neural network is effectively organized can be deduced. A self-organizing multilayered neural network, which is named "cognitron", is constructed following this algorithm, and is simulated on a digital computer. Unlike the organization of a usual brain models such as a three-layered perceptron, the self-organization of a cognitron progresses favorably without having a "teacher" which instructs in all particulars how the individual cells respond. After repetitive presentations of several stimulus patterns, the cognitron is self-organized in such a way that the receptive fields of the cells become relatively larger in a deeper layer. Each cell in the final layer integrates the information from

At present, however, the algorithm with which a neural network is self-organized is not known. Although several hypothesis for it have been proposed, none of them has been physiologically substantiated.

The three-layered perceptron proposed by Rosenblatt (1962) is one of the examples of the brain models based on such hypotheses. For a while after the perceptron was proposed, its capability for information processing was greatly expected, and many research works on it have been made. With the progress of the researches, however, it was gradually revealed that the capability of the perceptron is not so large as it had been expected at the beginning.

Although the perceptron consists of only three

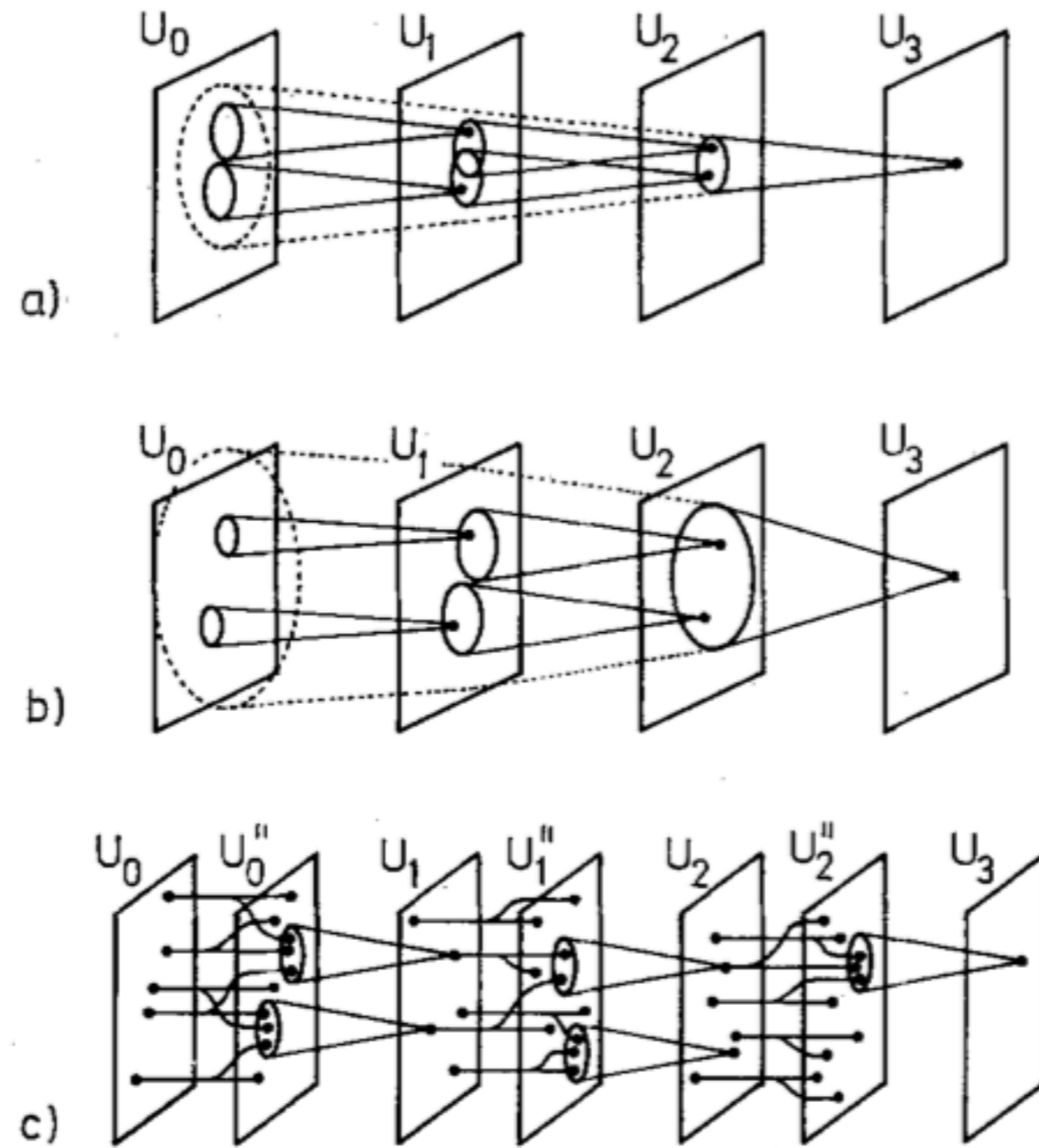

Fig. 4a-c. Three possible methods for interconnecting layers. The connectable area of each cell is differently chosen in these three methods. Method c is adopted for the cognitron discussed in this paper

# Gradient-Based Learning Applied to Document Recognition

Yann LeCun, Léon Bottou, Yoshua Bengio, and Patrick Haffner

*Abstract*—

Multilayer Neural Networks trained with the backpropagation algorithm constitute the best example of a successful Gradient-Based Learning technique. Given an appropriate network architecture, Gradient-Based Learning algorithms can be used to synthesize a complex decision surface that can classify high-dimensional patterns such as handwritten characters, with minimal preprocessing. This paper reviews various methods applied to handwritten character recognition and compares them on a standard handwritten digit recognition task. Convolutional Neural Networks, that are specifically designed to deal with the variability of 2D shapes, are shown to outperform all other techniques.

Real-life document recognition systems are composed of multiple modules including field extraction, segmentation, recognition, and language modeling. A new learning paradigm, called Graph Transformer Networks (GTN), allows such multi-module systems to be trained globally using Gradient-Based methods so as to minimize an overall performance measure.

Two systems for on-line handwriting recognition are described. Experiments demonstrate the advantage of global training, and the flexibility of Graph Transformer Networks.

A Graph Transformer Network for reading bank check is also described. It uses Convolutional Neural Network character recognizers combined with global training techniques to provide record accuracy on business and personal checks. It is deployed commercially and reads several million checks per day.

## I. INTRODUCTION

Over the last several years, machine learning techniques, particularly when applied to neural networks, have played an increasingly important role in the design of pattern recognition systems. In fact, it could be argued that the availability of learning techniques has been a crucial factor in the recent success of pattern recognition applications such as continuous speech recognition and handwriting recognition.

The main message of this paper is that better pattern recognition systems can be built by relying more on automatic learning, and less on hand-designed heuristics. This is made possible by recent progress in machine learning and computer technology. Using character recognition as a case study, we show that hand-crafted feature extraction can be advantageously replaced by carefully designed learning machines that operate directly on pixel images. Using document understanding as a case study, we show that the traditional way of building recognition systems by manually integrating individually designed modules can be replaced by a unified and well-principled design paradigm, called *Graph Transformer Networks*, that allows training



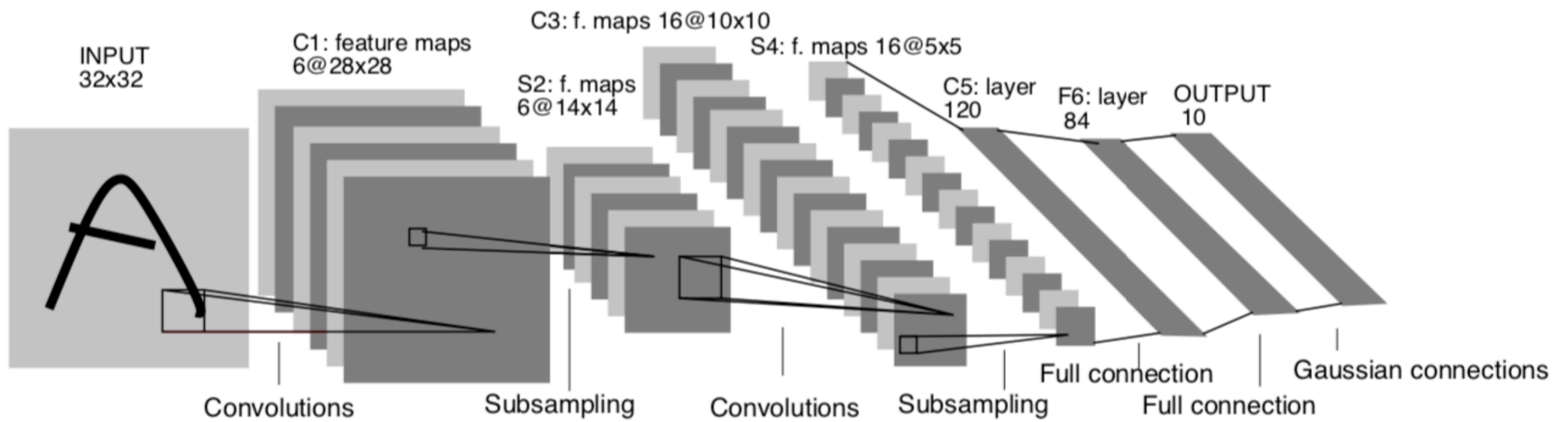
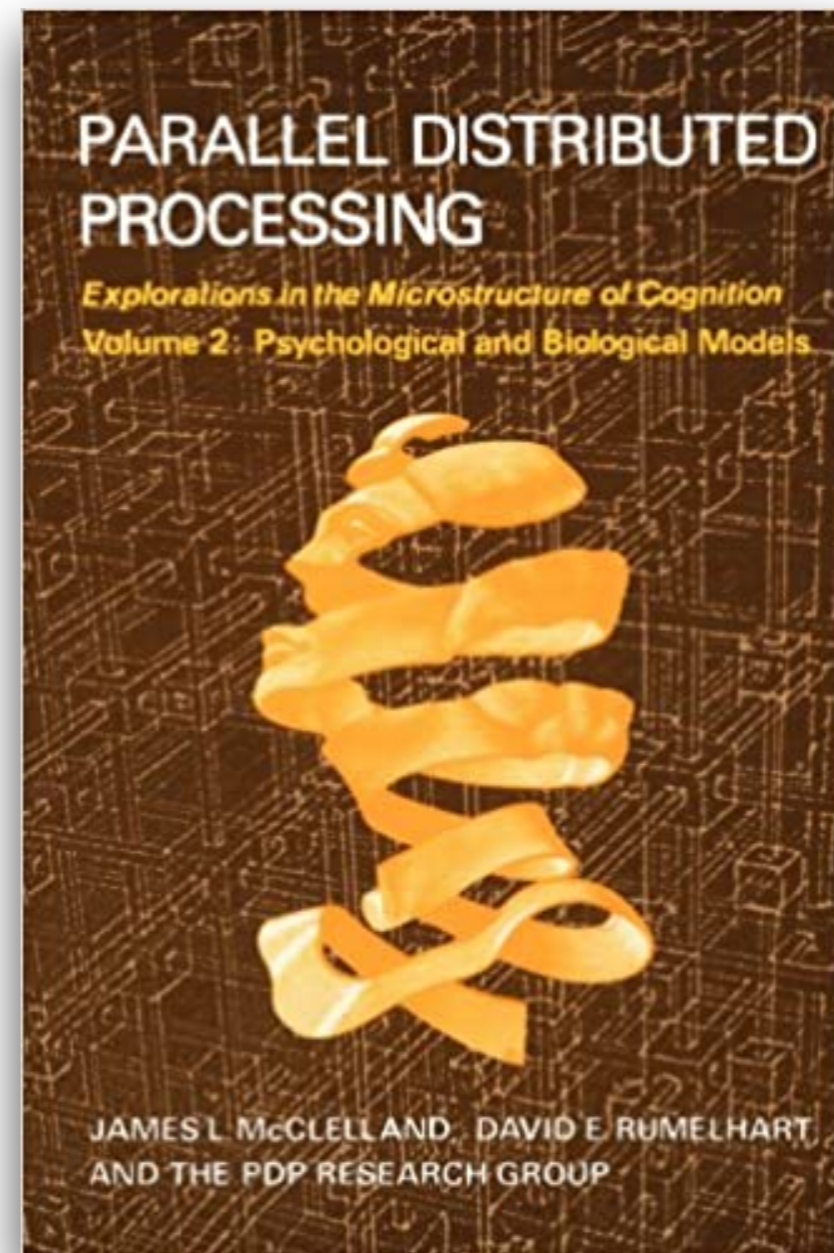
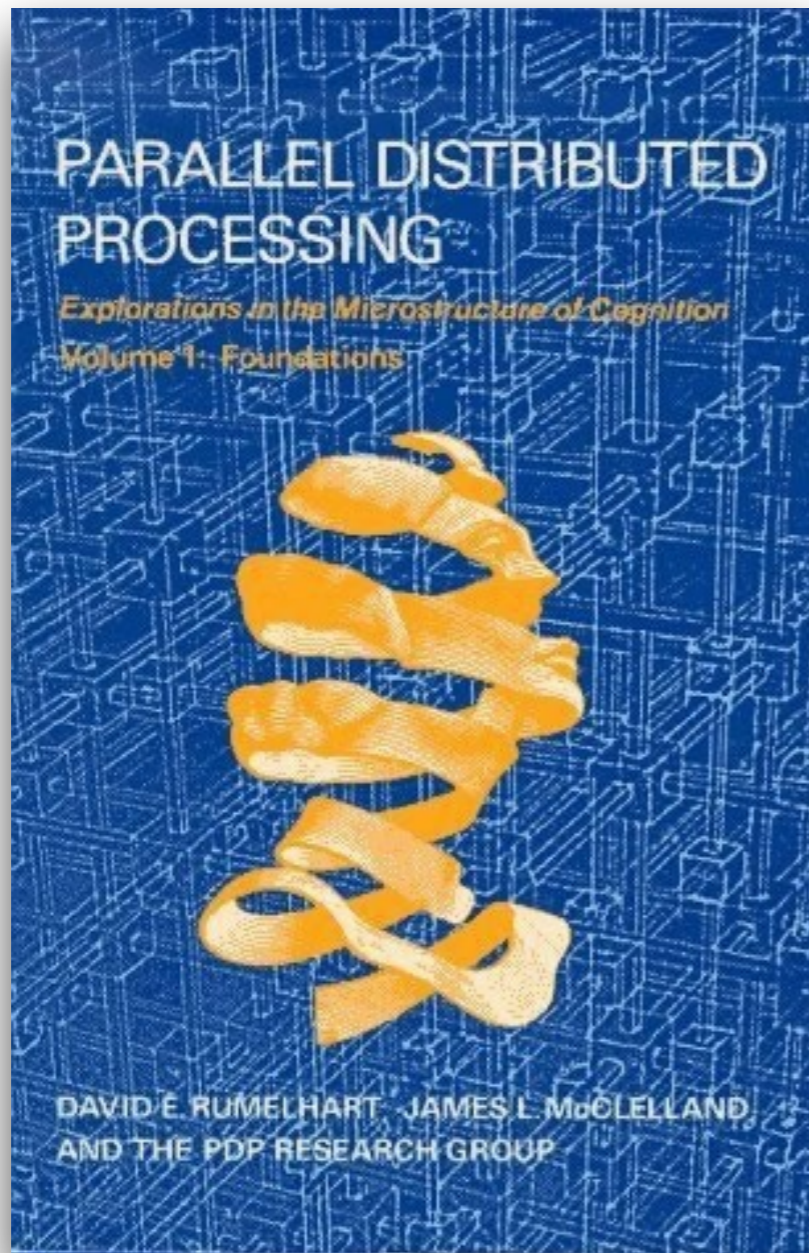

Fig. 2. Architecture of LeNet-5, a Convolutional Neural Network, here for digits recognition. Each plane is a feature map, i.e. a set of units whose weights are constrained to be identical.

# Connectionism

- ▶ The second wave of neural network research was in 1980s and started in the cognitive science. It was called connectionism or parallel distributed processing.
  - ▶ This followed the first winter (mid 70s-1980).
- ▶ The focus was on devising models of cognition combining symbolic reasoning and artificial neural network models.
- ▶ Many ideas are inspired by Hebb's models.
- ▶ The idea of *distributed representation*, i.e., using the raw data without devising features or pre-categorisation of the inputs was introduced by this research movement.
- ▶ The other key contribution of connectionism was the development of the *back-propagation algorithm* for training neural networks, which is central in deep learning.



# Second AI Winter and Current AI Summer

- ▶ The second wave of neural networks lasted until mid 1990s.
  - ▶ Loss of interest and lot of disappointment due to unrealistic goals led to a new “winter”.
- ▶ During the second winter, a lot of work continued especially in Canada (and NYU).
- ▶ The summer returned in 2006 when Geoffrey Hinton showed that a particular neural network called a deep belief network could be very efficiently trained (the strategy is called *greedy layer-wise pre-training*).

# A fast learning algorithm for deep belief nets \*

**Geoffrey E. Hinton** and **Simon Osindero**

Department of Computer Science University of Toronto  
10 Kings College Road  
Toronto, Canada M5S 3G4  
{hinton, osindero}@cs.toronto.edu

**Yee-Whye Teh**

Department of Computer Science  
National University of Singapore  
3 Science Drive 3, Singapore, 117543  
tehyw@comp.nus.edu.sg

## Abstract

We show how to use “complementary priors” to eliminate the explaining away effects that make inference difficult in densely-connected belief nets that have many hidden layers. Using complementary priors, we derive a fast, greedy algorithm that can learn deep, directed belief networks one layer at a time, provided the top two layers form an undirected associative memory. The fast, greedy algorithm is used to initialize a slower learning procedure that fine-tunes the weights using a contrastive version of the wake-sleep algorithm. After fine-tuning, a network with three hidden layers forms a very good generative model of the joint distribution of handwritten digit images and their labels. This generative model gives better digit classification than the best discriminative learning algorithms. The low-dimensional manifolds on which the digits lie are modelled by

remaining hidden layers form a directed acyclic graph that converts the representations in the associative memory into observable variables such as the pixels of an image. This hybrid model has some attractive features:

1. There is a fast, greedy learning algorithm that can find a fairly good set of parameters quickly, even in deep networks with millions of parameters and many hidden layers.
2. The learning algorithm is unsupervised but can be applied to labeled data by learning a model that generates both the label and the data.
3. There is a fine-tuning algorithm that learns an excellent generative model which outperforms discriminative methods on the MNIST database of hand-written digits.
4. The generative model makes it easy to interpret the distributed representations in the deep hidden layers.
5. The inference required for forming a percept is both fast

# Networks and Computational Graphs

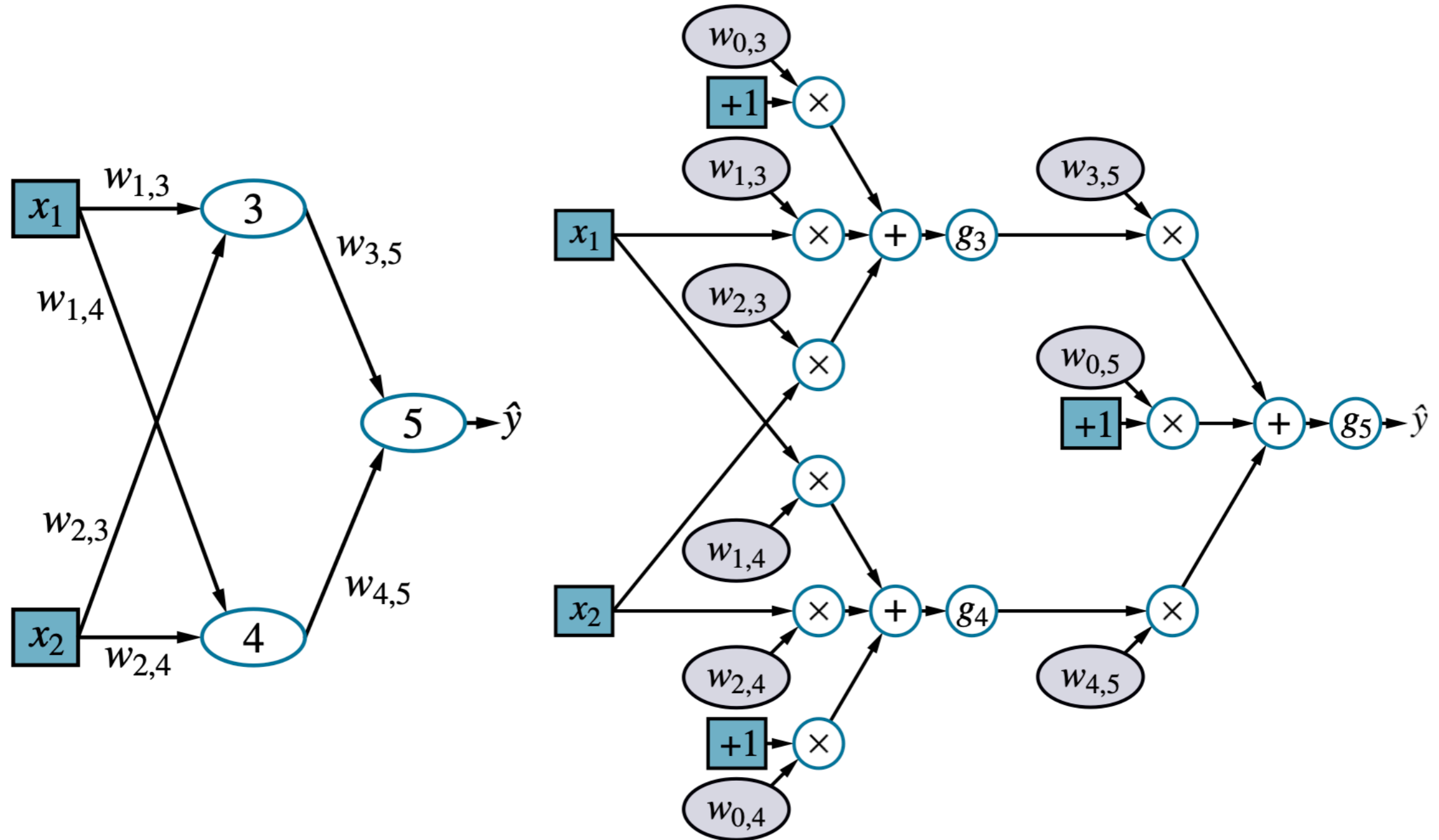

From: Stuart Russell and Peter Norvig. Introduction to Artificial Intelligence. 4th Edition. 2020.

# Deep Learning Applications

- ▶ The number of application of deep learning is increasing everyday:
  - ▶ Image and video processing and vision;
  - ▶ Machine translation;
  - ▶ Speech generation;
  - ▶ Applications to many scientific fields (astronomy, biology, etc.).
    - ▶ See for example the problem of protein folding.
- ▶ One of the biggest achievement is the extension of the domain of reinforcement learning.
  - ▶ We refer to the convergence of deep learning and reinforcement learning as *deep reinforcement learning*.
  - ▶ Applications of deep reinforcement learning include games, robotics, etc.

# Convolutional Networks

|   |   |   |
|---|---|---|
| 0 | 1 | 0 |
| 1 | 0 | 1 |
| 0 | 1 | 0 |

|     |    |     |     |     |
|-----|----|-----|-----|-----|
| 128 | 97 | 53  | 201 | 198 |
| 35  | 22 | 25  | 200 | 195 |
| 37  | 24 | 28  | 197 | 182 |
| 33  | 28 | 92  | 195 | 179 |
| 31  | 40 | 100 | 192 | 177 |

|     |  |  |
|-----|--|--|
| 181 |  |  |
|     |  |  |
|     |  |  |

- ▶ *Convolutional networks* are networks that contain a mix of convolutional layers, pooling layers and dense layers.
- ▶ A *convolutional layer* is a layer of a deep neural network, which contains a convolutional filter.
- ▶ A convolutional filter is a matrix having the same rank as the input matrix but a smaller shape.



# Convolutional Networks

|   |   |   |
|---|---|---|
| 5 | 3 | 1 |
| 8 | 2 | 5 |
| 9 | 4 | 3 |

- ▶ A *pooling layer* reduces a matrix (or matrices created by an earlier convolutional layer) to a smaller matrix. Pooling usually involves taking either maximum or average value across the pooled area.

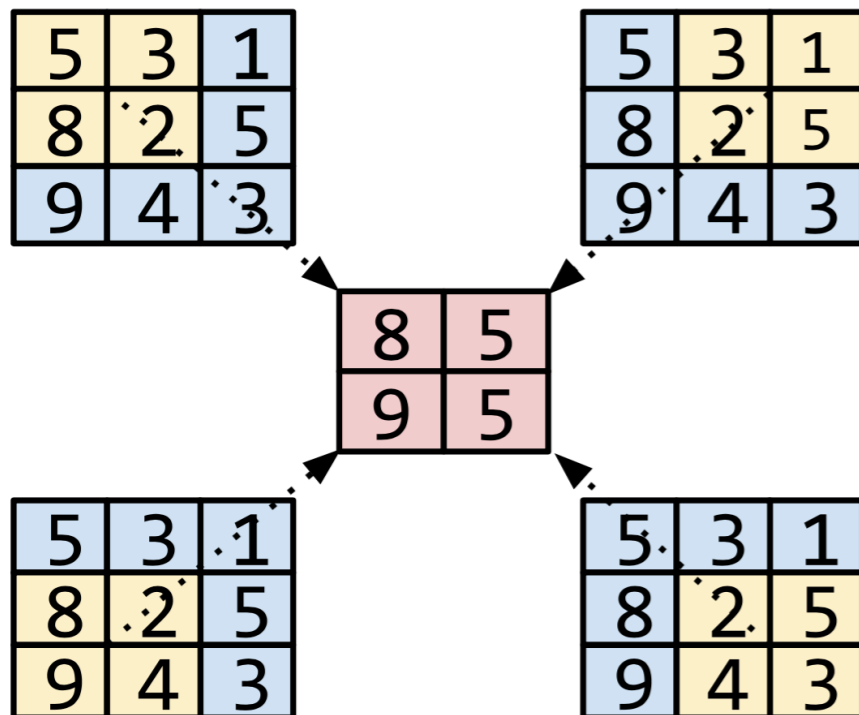

- ▶ A *pooling operation* divides the matrix into slices and then slides that convolutional operation by strides.
- ▶ A *stride* is the delta in each dimension of the convolutional operation.

# Convolutional Networks

|   |   |   |
|---|---|---|
| 5 | 3 | 1 |
| 8 | 2 | 5 |
| 9 | 4 | 3 |

- ▶ Pooling helps enforce translational invariance, which allows algorithms to classify images when the position of the objects within the images change, in the input matrix.

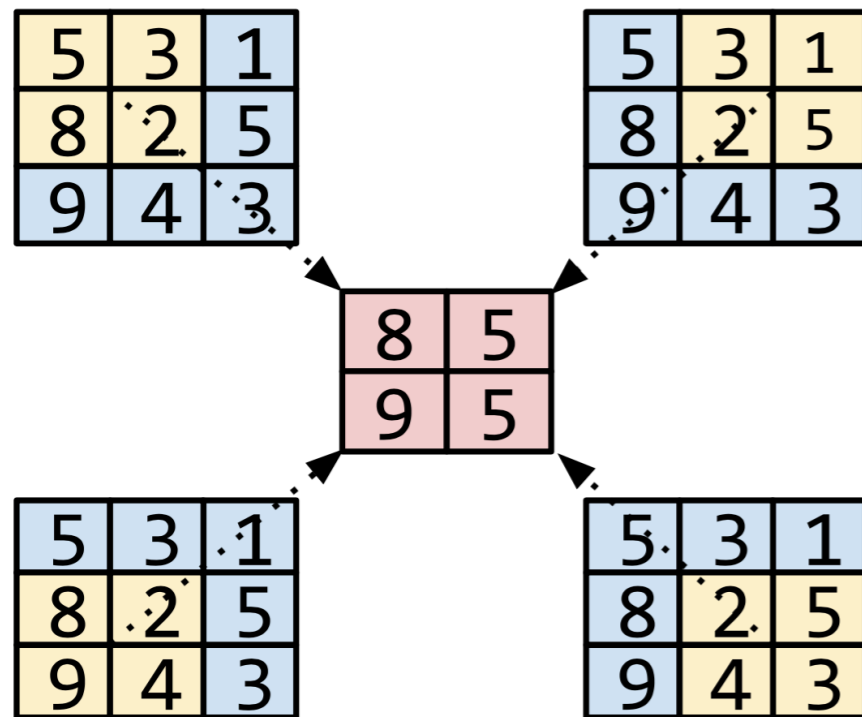

- ▶ Pooling for vision applications is usually called *spatial pooling*.
- ▶ Pooling for time-series applications is usually referred to as *temporal pooling*.
- ▶ You can also hear the expressions *subsampling* and *downsampling*.

# Recurrent Neural Networks

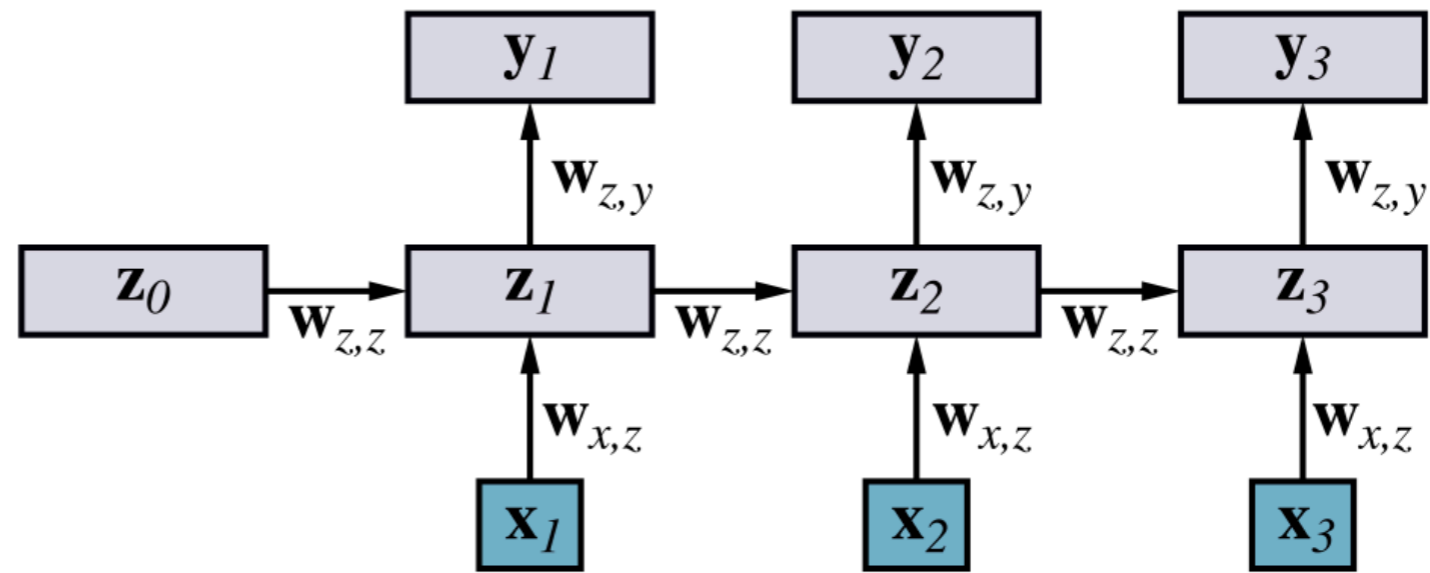
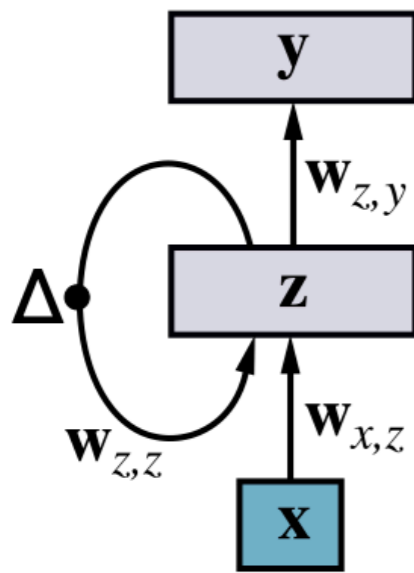

# LSTMs

- ▶ It is a kind of RNN that does not suffer from the problem of vanishing gradients.
- ▶ In fact, an LSTM can choose to remember part of the input, copying it over to the next time step and to forget other parts.
- ▶ LSTM stands for long short-term memory. LSTM is a kind of RNN with gating units.

# LONG SHORT-TERM MEMORY

NEURAL COMPUTATION 9(8):1735–1780, 1997

Sepp Hochreiter

Fakultät für Informatik

Technische Universität München

80290 München, Germany

hochreit@informatik.tu-muenchen.de

<http://www7.informatik.tu-muenchen.de/~hochreit>

Jürgen Schmidhuber

IDSIA

Corso Elvezia 36

6900 Lugano, Switzerland

juergen@idsia.ch

<http://www.idsia.ch/~juergen>

## Abstract

Learning to store information over extended time intervals via recurrent backpropagation takes a very long time, mostly due to insufficient, decaying error back flow. We briefly review Hochreiter's 1991 analysis of this problem, then address it by introducing a novel, efficient, gradient-based method called "Long Short-Term Memory" (LSTM). Truncating the gradient where this does not do harm, LSTM can learn to bridge minimal time lags in excess of 1000 discrete time steps by enforcing *constant* error flow through "constant error carousels" within special units. Multiplicative gate units learn to open and close access to the constant error flow. LSTM is local in space and time; its computational complexity per time step and weight is  $O(1)$ . Our experiments with artificial data involve local, distributed, real-valued, and noisy pattern representations. In comparisons with RTRL, BPTT, Recurrent Cascade-Correlation, Elman nets, and Neural Sequence Chunking, LSTM leads to many more successful runs, and learns much faster. LSTM also solves complex, artificial long time lag tasks that have never

# Residual Networks

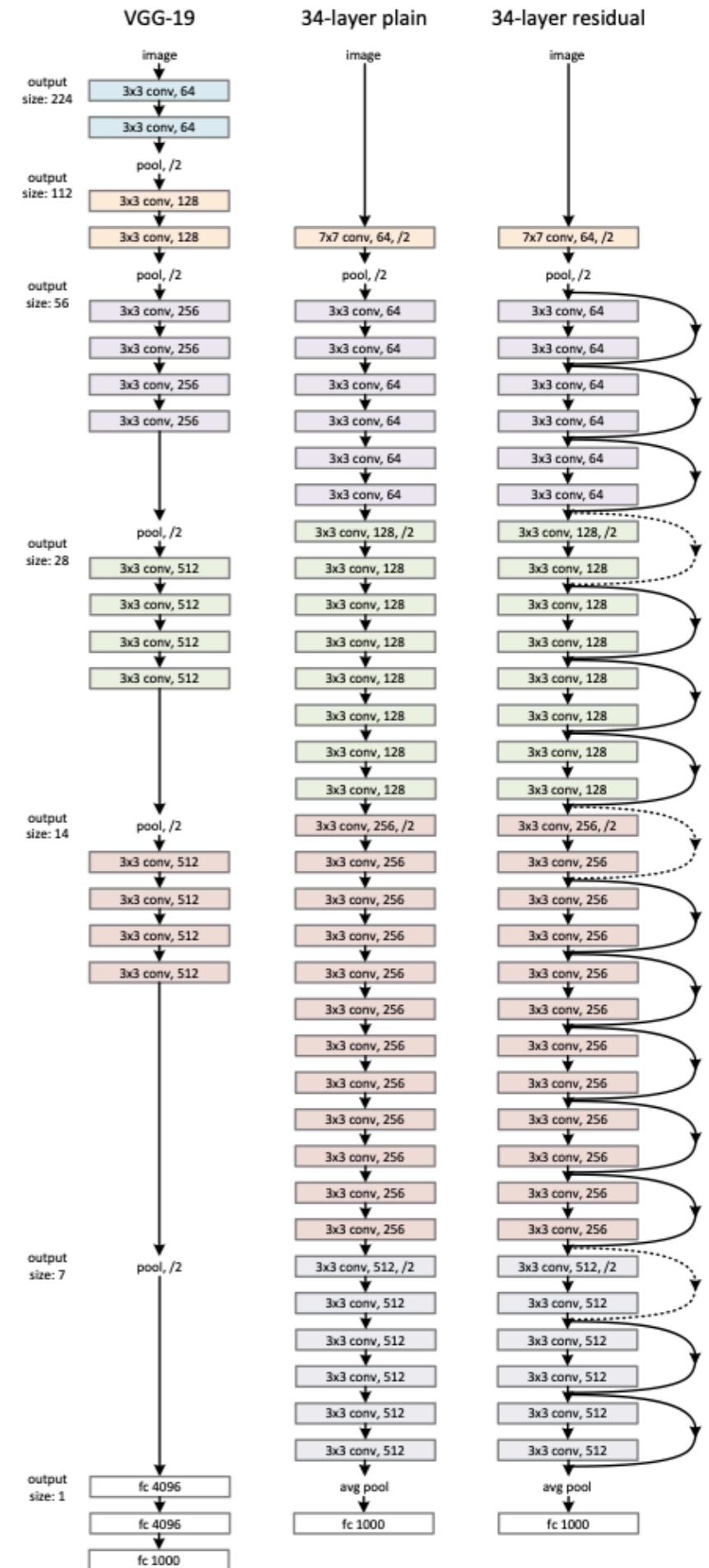
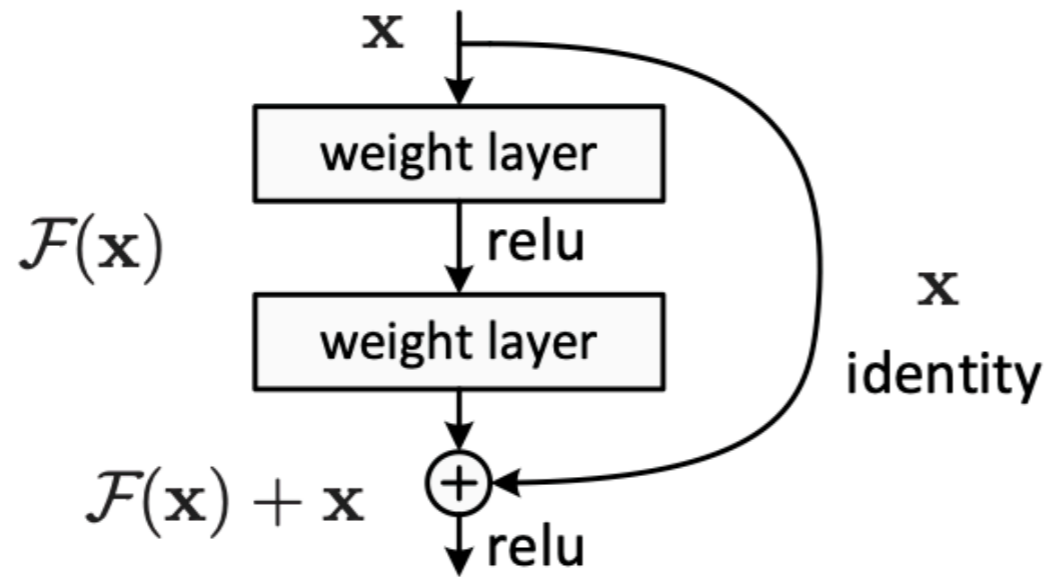

# Neuroscience and Deep Learning: Some Caveats

- ▶ Neuroscience can be an inspiration, but we should remember that we are trying to “engineer” a system.
- ▶ Actual neurons are not based on the simple functions that we use in our systems.
  - ▶ At the moment, more complex functions haven’t led to improve performance yet.
- ▶ Neuroscience has inspired the design of several neural architectures, but our knowledge is limited in terms of how the brain actually learn.
- ▶ For this reason, neuroscience is of limited help for improving the design of the learning algorithms themselves.
- ▶ Deep learning is not an attempt to simulate the brain!

# Deep Learning and Computational Neuroscience

- ▶ At the same time, it is worth noting that there is an entire field of neuroscience devoted to understanding the brain using mathematical and computational models. The area is called *computational neuroscience*.
- ▶ AI and neuroscience are strictly linked and indeed understanding brain biology will lead to improvement in the design of AI systems.
- ▶ This is currently an area of intense research.



# Neuroscience-Inspired Artificial Intelligence

Demis Hassabis,<sup>1,2,\*</sup> Dharshan Kumaran,<sup>1,3</sup> Christopher Summerfield,<sup>1,4</sup> and Matthew Botvinick<sup>1,2</sup>

<sup>1</sup>DeepMind, 5 New Street Square, London, UK

<sup>2</sup>Gatsby Computational Neuroscience Unit, 25 Howland Street, London, UK

<sup>3</sup>Institute of Cognitive Neuroscience, University College London, 17 Queen Square, London, UK

<sup>4</sup>Department of Experimental Psychology, University of Oxford, Oxford, UK

\*Correspondence: [dhcontact@google.com](mailto:dhcontact@google.com)

<http://dx.doi.org/10.1016/j.neuron.2017.06.011>

The fields of neuroscience and artificial intelligence (AI) have a long and intertwined history. In more recent times, however, communication and collaboration between the two fields has become less commonplace. In this article, we argue that better understanding biological brains could play a vital role in building intelligent machines. We survey historical interactions between the AI and neuroscience fields and emphasize current advances in AI that have been inspired by the study of neural computation in humans and other animals. We conclude by highlighting shared themes that may be key for advancing future research in both fields.

In recent years, rapid progress has been made in the related fields of neuroscience and artificial intelligence (AI). At the dawn of the computer age, work on AI was inextricably intertwined with neuroscience and psychology, and many of the early pioneers straddled both fields, with collaborations between these disciplines proving highly productive (Churchland and Sejnowski, 1988; Hebb, 1949; Hinton et al., 1986; Hopfield, 1982; McCulloch and Pitts, 1943; Turing, 1950). However, more recently, the interaction has become much less commonplace, as both subjects have grown enormously in complexity and disciplinary boundaries have solidified. In this review, we argue for the critical and ongoing importance of neuroscience in generating ideas that will accelerate and guide AI research

tively. For example, if an algorithm is not quite attaining the level of performance required or expected, but we observe it is core to the functioning of the brain, then we can surmise that redoubled engineering efforts geared to making it work in artificial systems are likely to pay off.

Of course from a practical standpoint of building an AI system, we need not slavishly enforce adherence to biological plausibility. From an engineering perspective, what works is ultimately all that matters. For our purposes then, biological plausibility is a guide, not a strict requirement. What we are interested in is a systems neuroscience-level understanding of the brain, namely the algorithms, architectures, functions, and representations it utilizes. This roughly corresponds to

# THEORETICAL NEUROSCIENCE

Computational and Mathematical  
Modeling of Neural Systems

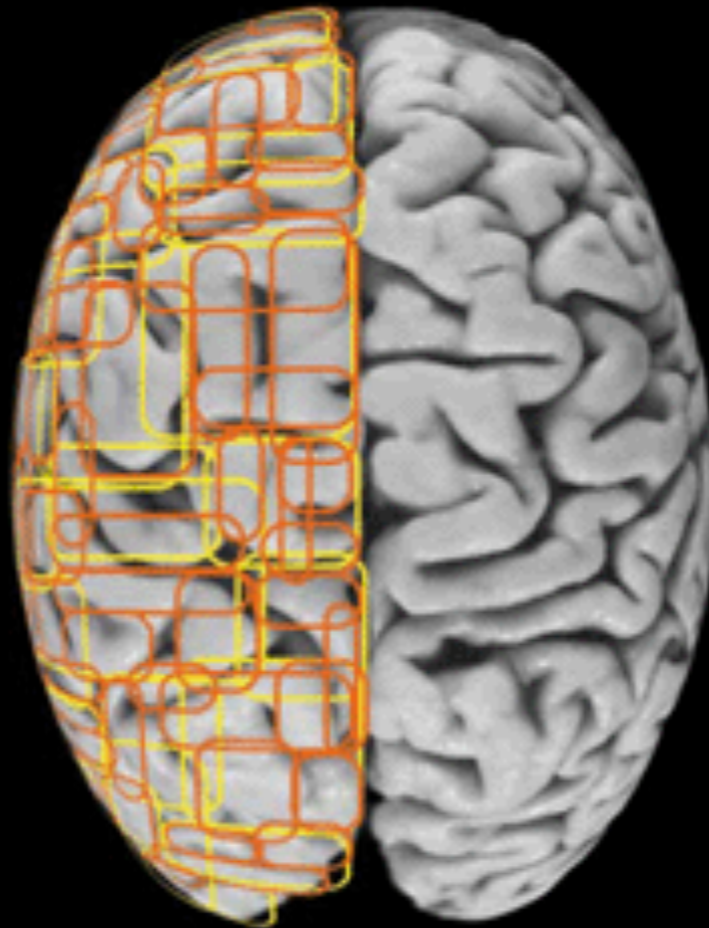

Peter Dayan and L. F. Abbott

# Superintelligence

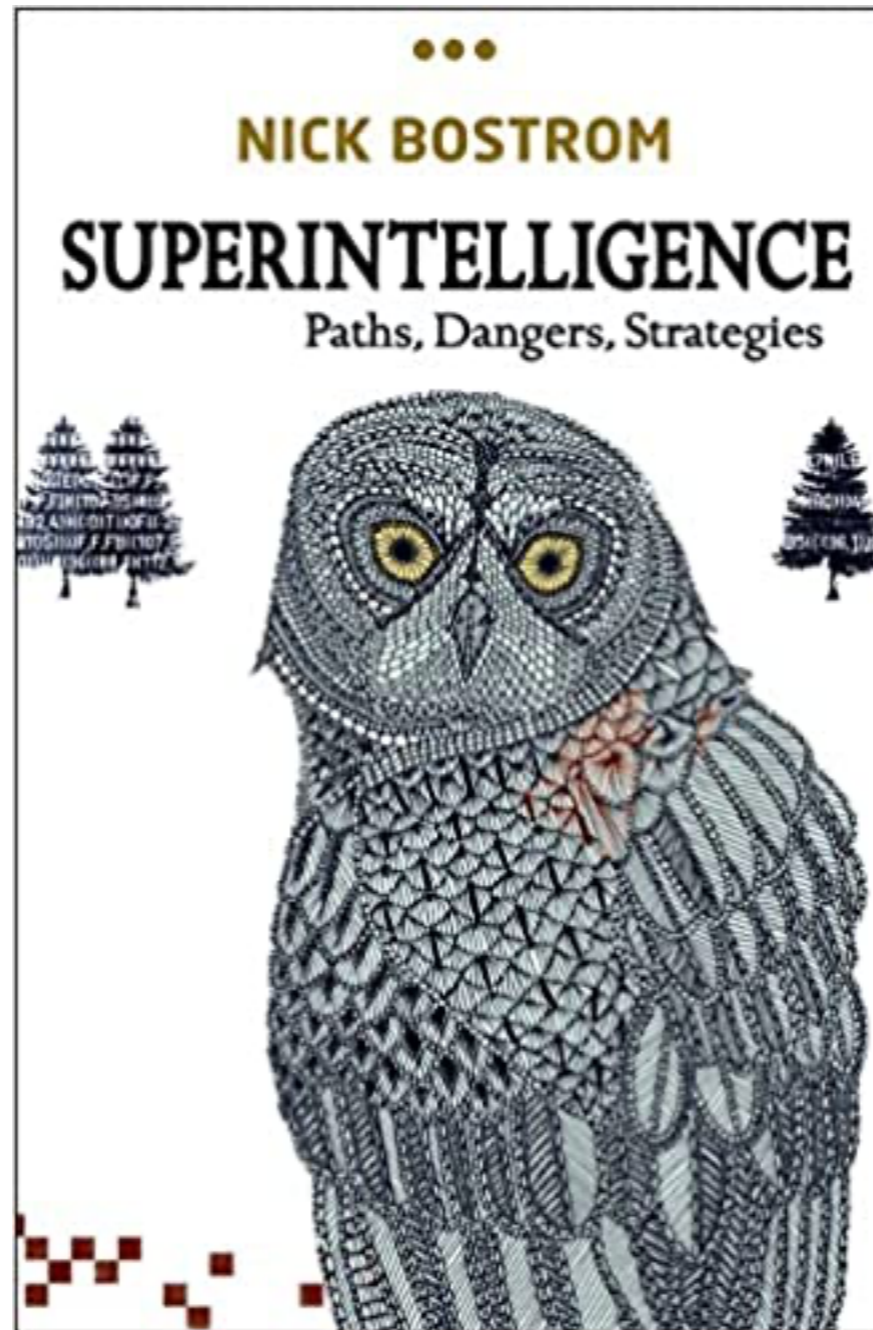

# ARE YOU LIVING IN A COMPUTER SIMULATION?

BY NICK BOSTROM

[Published in *Philosophical Quarterly* (2003) Vol. 53, No. 211, pp. 243-255. (First version: 2001)]

This paper argues that *at least one* of the following propositions is true: (1) the human species is very likely to go extinct before reaching a “posthuman” stage; (2) any posthuman civilization is extremely unlikely to run a significant number of simulations of their evolutionary history (or variations thereof); (3) we are almost certainly living in a computer simulation. It follows that the belief that there is a significant chance that we will one day become posthumans who run ancestor-simulations is false, unless we are currently living in a simulation. A number of other consequences of this result are also discussed.

## I. INTRODUCTION

Many works of science fiction as well as some forecasts by serious technologists and futurologists predict that enormous amounts of computing power will be

# Is the Singularity near?

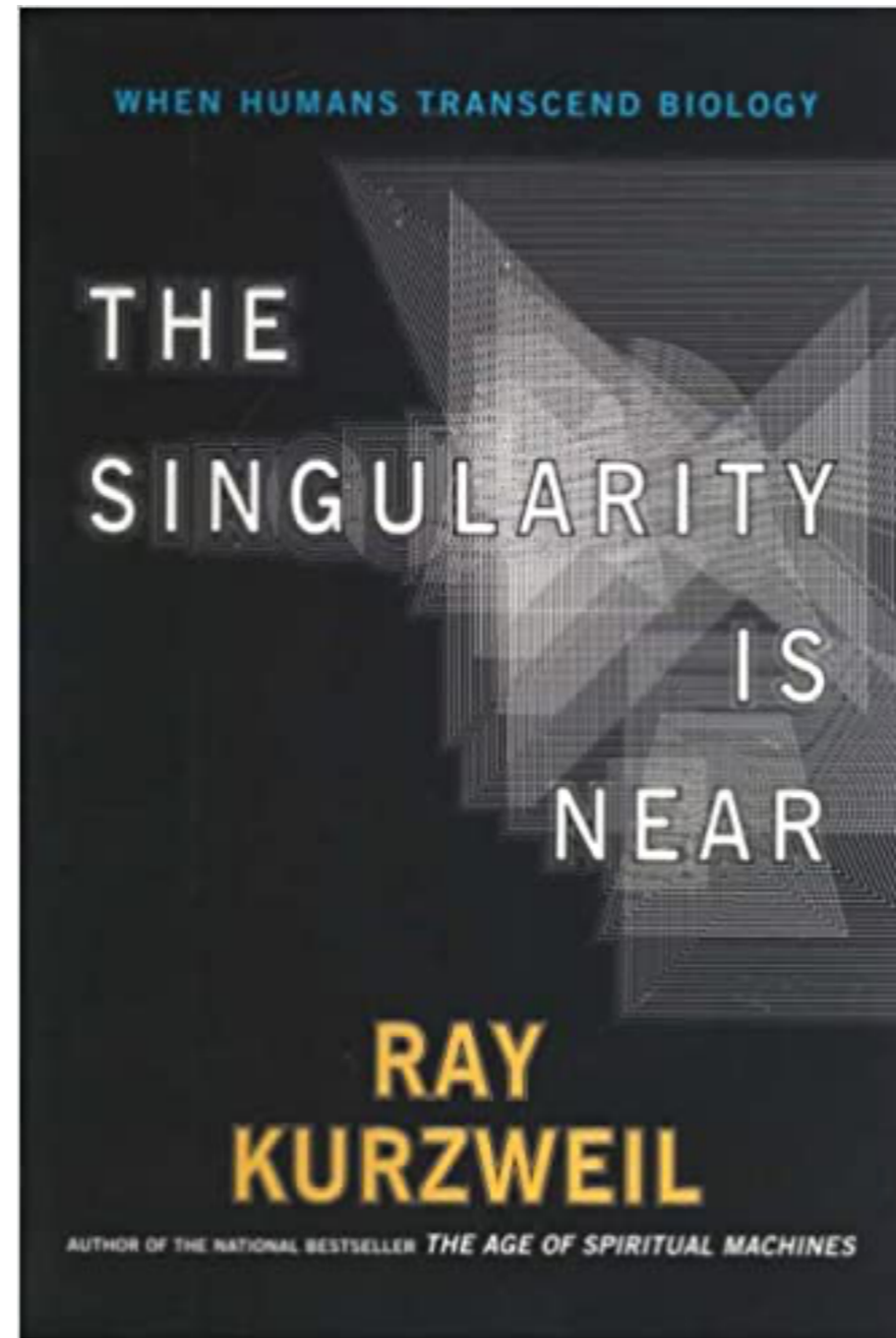

# 120 Years of Moore's Law

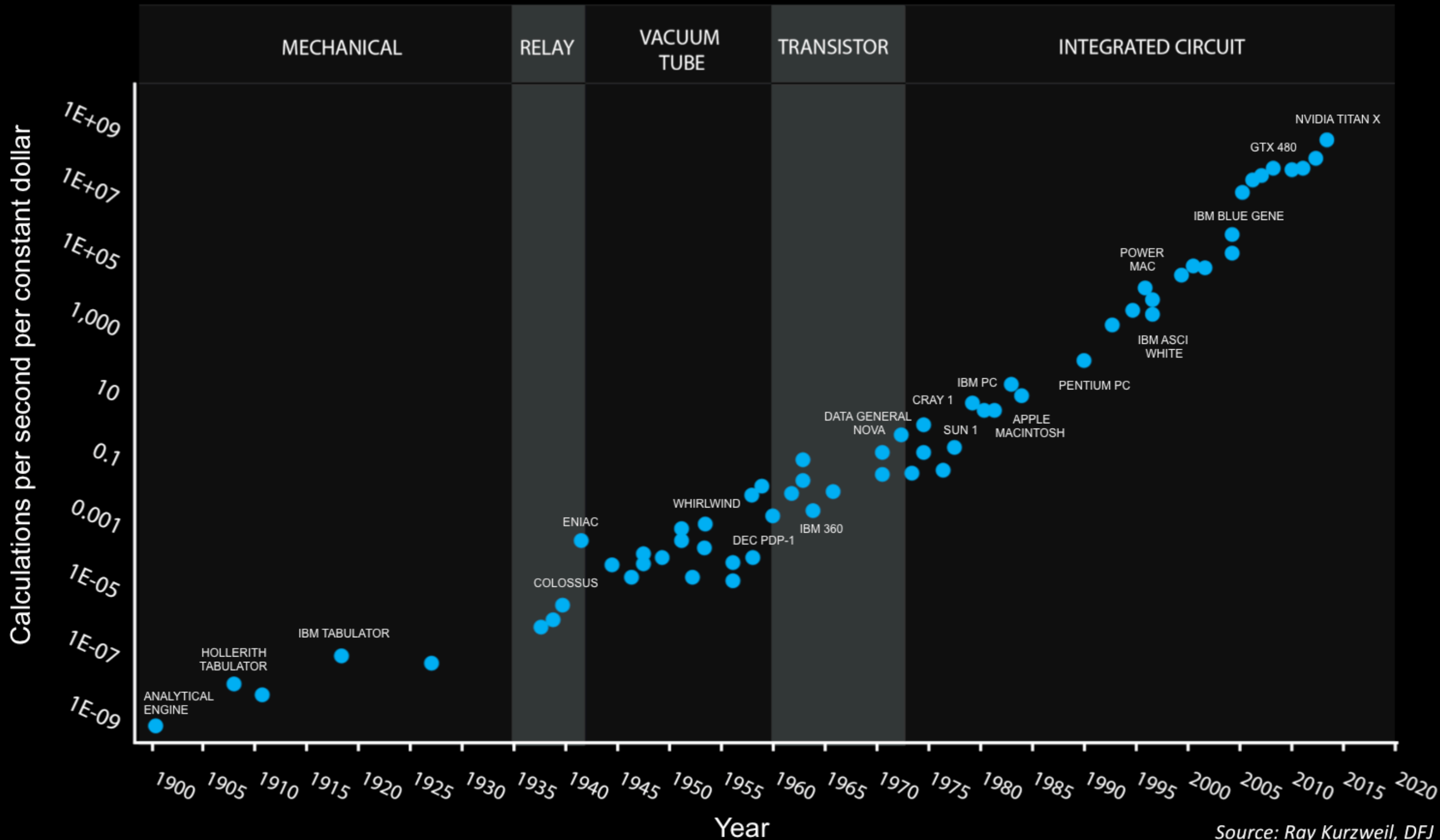

Source: Ray Kurzweil, DFJ

# Exponential Growth of Computing

Twentieth through twenty first century

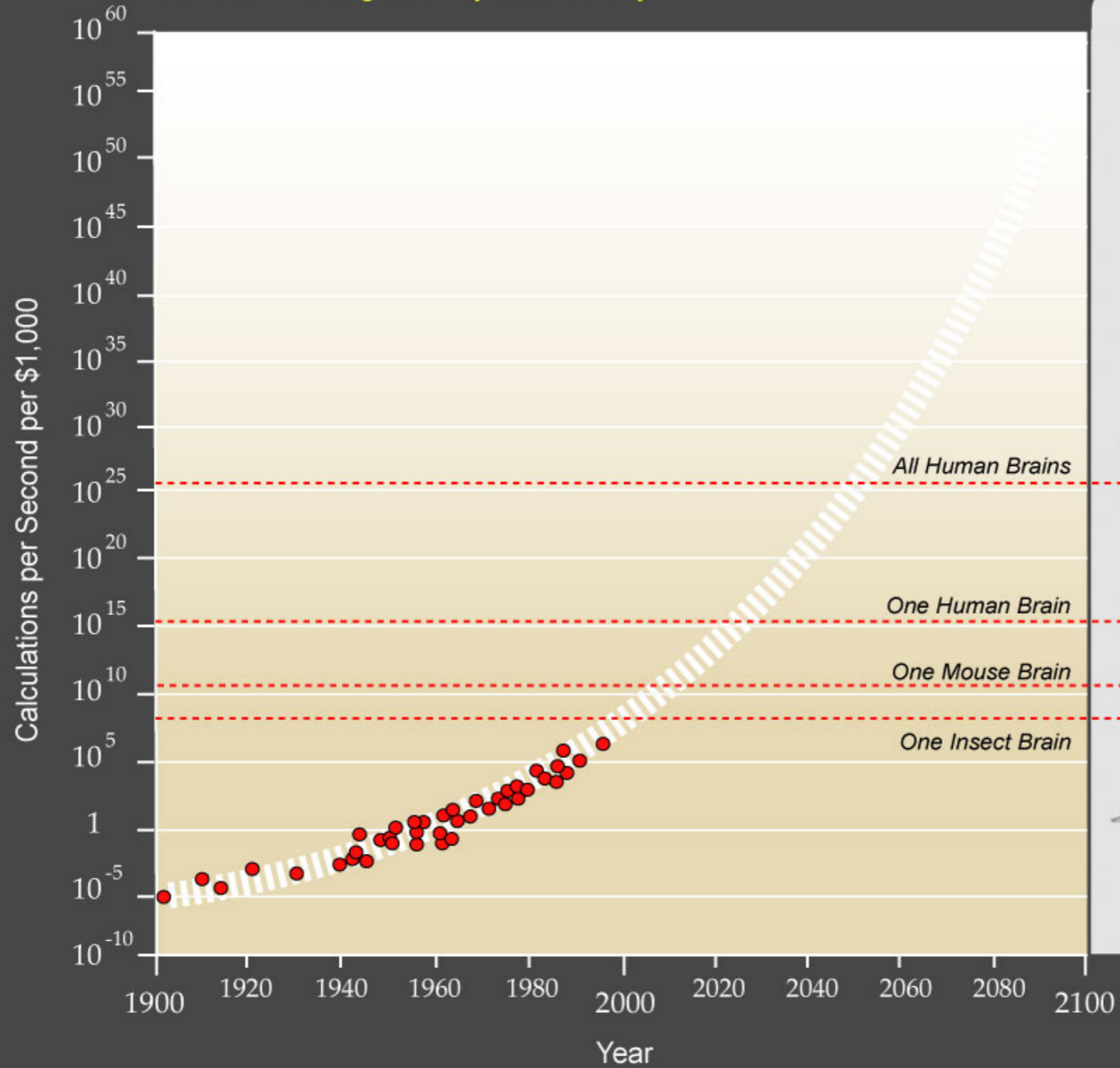

Logarithmic Plot



THE NEW YORK TIMES BESTSELLER



HOW TO  
**CREATE**  
A  
**MIND**

THE SECRET OF  
HUMAN THOUGHT REVEALED



**RAY KURZWEIL**

AUTHOR OF *THE SINGULARITY IS NEAR*



# Conscious Machines

REVIEWS

## Neural correlates of consciousness: progress and problems

*Christof Koch<sup>1</sup>, Marcello Massimini<sup>2,3</sup>, Melanie Boly<sup>4,5</sup> and Giulio Tononi<sup>5</sup>*

**Abstract** | There have been a number of advances in the search for the neural correlates of consciousness — the minimum neural mechanisms sufficient for any one specific conscious percept. In this Review, we describe recent findings showing that the anatomical neural correlates of consciousness are primarily localized to a posterior cortical hot zone that includes sensory areas, rather than to a fronto-parietal network involved in task monitoring and reporting. We also discuss some candidate neurophysiological markers of consciousness that have proved illusory, and measures of differentiation and integration of neural activity that offer more promising quantitative indices of consciousness.

**Neural correlates of consciousness (NCC).** The minimum neural mechanisms jointly sufficient for any one specific conscious experience.

Being conscious means that one is having an experience — the subjective, phenomenal ‘what it is like’ to see an image, hear a sound, think a thought or feel an emotion. Although our waking experiences usually refer to the external world, we continue to be conscious when we day-dream and during those periods of sleep when we dream<sup>1</sup>. Consciousness only vanishes during dreamless sleep or

This Review focuses on visual and auditory studies; for accounts of the NCC for metacognition, body, tactile and olfactory experiences, see REFS 4–7.

### **Behavioural correlates of consciousness**

Although experiences are private, we can usually infer that people are conscious if they are awake and act purpose-

# Conscious Machines

Trends in Cognitive Sciences

CellPress

## Review

# No-Report Paradigms: Extracting the True Neural Correlates of Consciousness

Naotsugu Tsuchiya,<sup>1,2,\*</sup> Melanie Wilke,<sup>3,4,5</sup> Stefan Frässle,<sup>6</sup> and Victor A.F. Lamme<sup>7</sup>

**The goal of consciousness research is to reveal the neural basis of phenomenal experience. To study phenomenology, experimenters seem obliged to ask reports from the subjects to ascertain what they experience. However, we argue that the requirement of reports has biased the search for the neural correlates of consciousness over the past decades. More recent studies attempt to dissociate neural activity that gives rise to consciousness from the activity that enables the report; in particular, no-report paradigms have been utilized to study conscious experience in the full absence of any report. We discuss the advantages and disadvantages of report-based and no-report paradigms, and ask how these jointly bring us closer to understanding the true neural basis of consciousness.**

### Trends

To study the neural correlates of consciousness (NCC), some forms of behavioral reports from subjects may seem absolutely necessary. However, strong reliance on reports has biased much of the NCC research towards the search for the neural correlates of perceptual reports.

Stringent requirement of behavioral reports not only overestimates the true NCC, owing to the inclusion of the neural correlates of reports, but also underestimates it because there are some aspects of real conscious experience that are fundamentally difficult to

**Looking for Consciousness in All The Wrong Places?**

# Alternative Minds

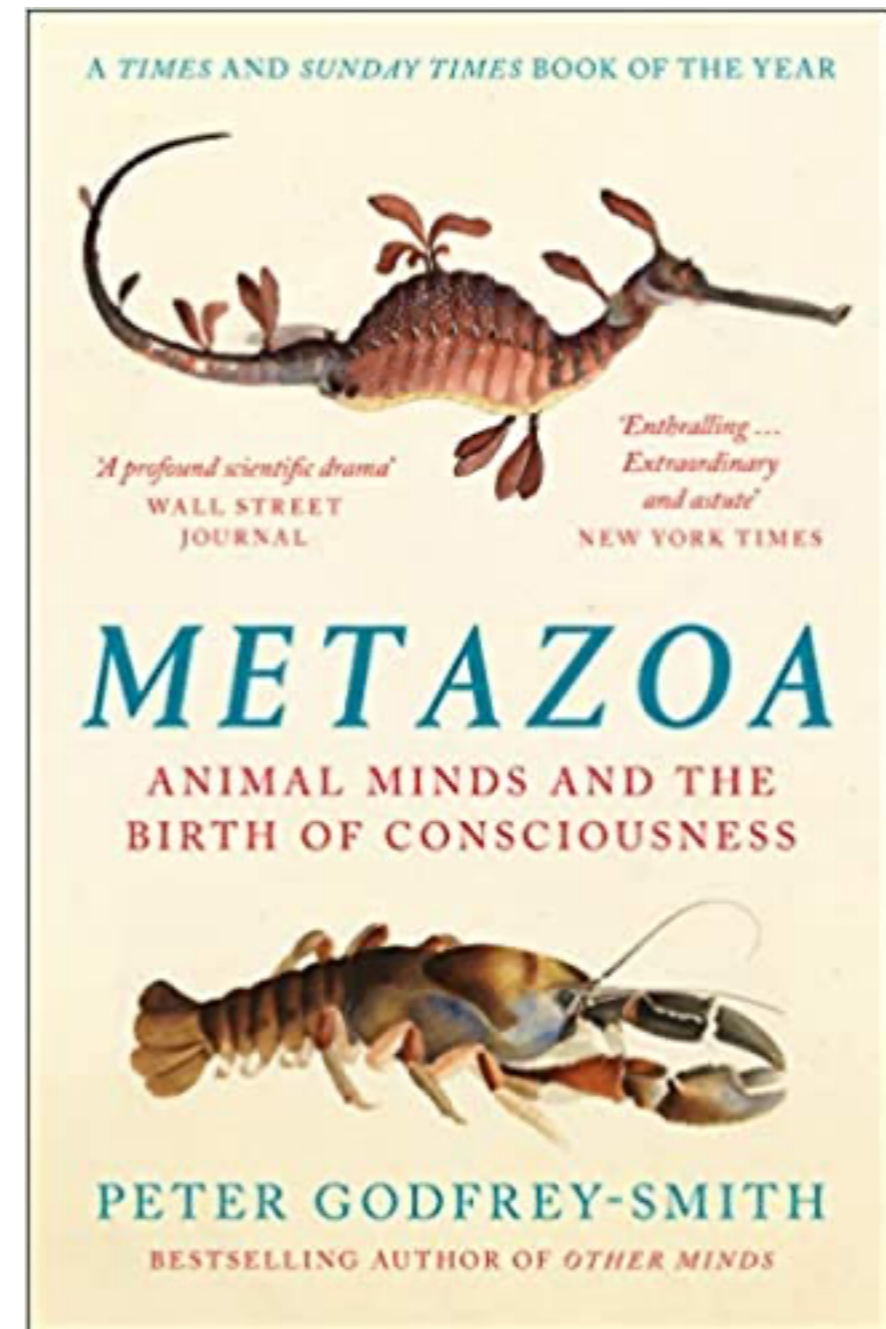
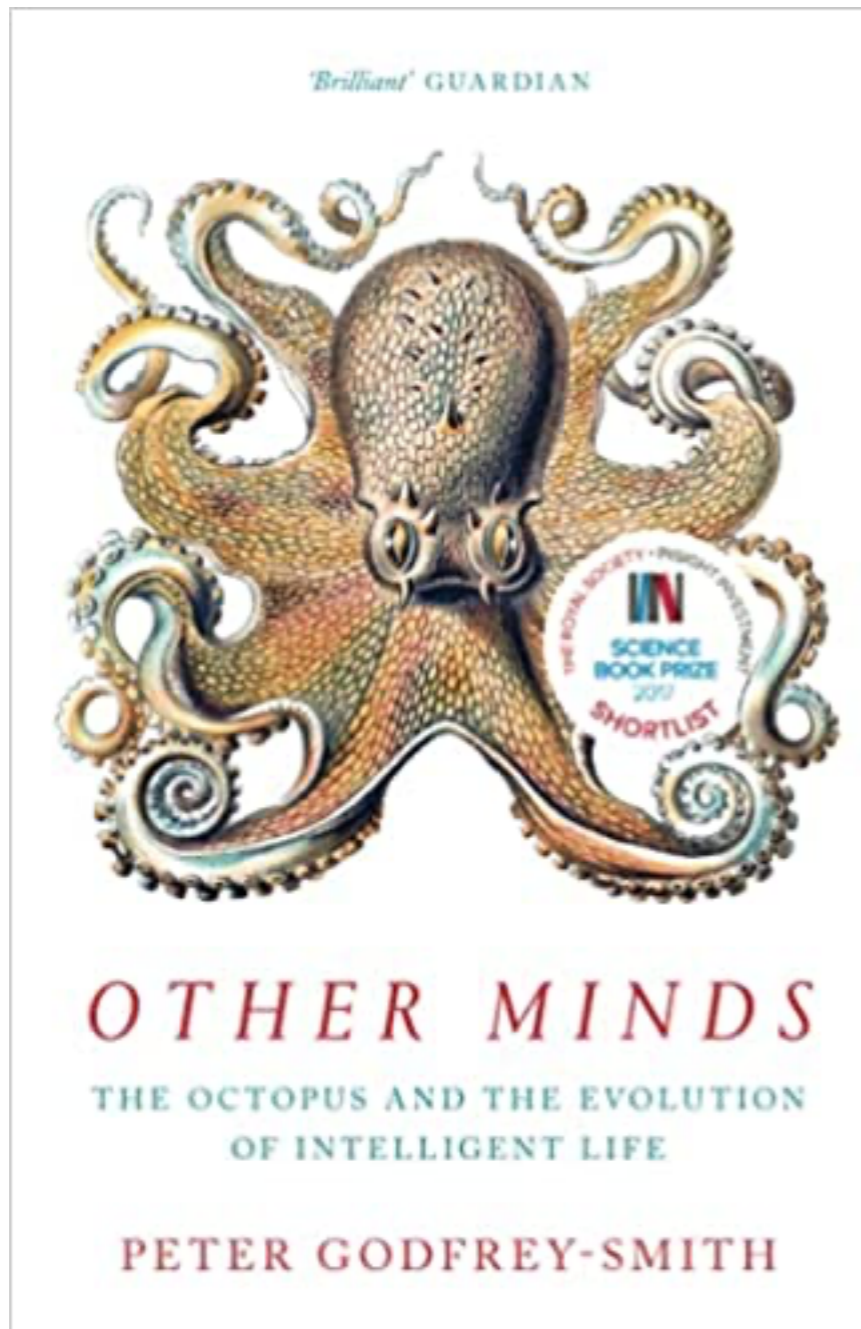

# The Brain-Computer Metaphor

**MINI REVIEW article**

Front. Comput. Sci., 08 February 2022 | <https://doi.org/10.3389/fcomp.2022.810358>



## The Brain-Computer Metaphor Debate Is Useless: A Matter of Semantics

 **Blake A. Richards**<sup>1,2,3,4\*</sup> and  **Timothy P. Lillicrap**<sup>5</sup>

<sup>1</sup>Mila, Montreal, QC, Canada

<sup>2</sup>Department of Neurology and Neurosurgery, Montreal Neurological Institute, McGill University, Montreal, QC, Canada

<sup>3</sup>School of Computer Science, McGill University, Montreal, QC, Canada

<sup>4</sup>Learning in Machines and Brains Program, CIFAR, Toronto, ON, Canada

<sup>5</sup>DeepMind Inc., London, United Kingdom

It is commonly assumed that usage of the word “computer” in the brain sciences reflects a metaphor. However, there is no single definition of the word “computer” in use. In fact, based on the usage of the word “computer” in computer science, a computer is merely some physical machinery that can in theory compute any computable function. According to this definition the brain is literally a computer; there is no metaphor. But, this deviates from how the word “computer” is used in other academic disciplines. According to the definition used outside of computer science, “computers” are human-made devices that engage in sequential processing of

# References

- ▶ Chapters 1, 16 and 20 of Ian Goodfellow, Yoshua Bengio and Aaron Courville. Deep Learning. MIT Press. 2016.

# Attribution Notice

- ▶ Portion of the material in the slides about convolutional networks, recurrent networks are modifications based on work created and [shared by Google](#) and used according to terms described in the [Creative Commons 4.0 Attribution License](#).
- ▶ Source: <https://developers.google.com/machine-learning/glossary/>
- ▶ Attribution license: <https://creativecommons.org/licenses/by/4.0/>